

ACTIVE INFRARED SENSORS

Brief descriptions and data sheets



APPLICATION

- Active infrared presence detector FLG 10-5M for detecting vehicles

FEATURES

- Triangular reflection light scanner with suppression of the foreground or background signal
- Insensitive to air turbulence, external light, sunlight and weather conditions (snow, rain, fog)

The presence detector FLG 10-5 M is a modification of the vehicle detector FLG 10-20 for the detection of road vehicles.

The presence detector FLG 10-5 M reliably detects vehicles (or persons and objects) within two monitored spacial cones.

Upon entrance of a vehicle, each of the two signal outputs is activated **without time limit** as long as the object or vehicle is within the monitoring area.

With the simultaneous use of both signal outputs and their external logical operation by means of AND or OR operations, the sensor can be used for object detection or for travel-direction detection.

The vehicle detector FLG is an infrared reflection sensor with defined suppression of the background signals, i.e. the vehicle or the detected object forms the reflector.

The detection range and the effectiveness of the background suppression can be adjusted by the user within a large range.

The detection range is dependent on the reflectivity of the vehicles to be detected. It is > 8 ... 10 m for black metallic paint and > 10 m for other colours.

For a safe detection of very flat vehicles, it is recommended to arrange the sensor at a height of 0.7 m above the road surface.

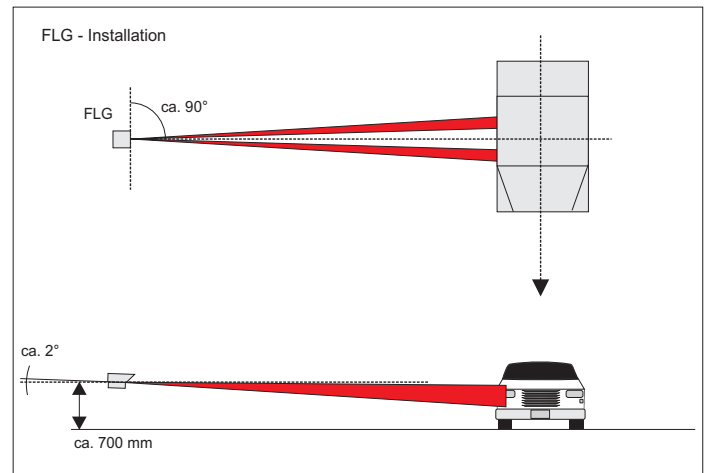

TECHNICAL DATA FLG 10-5 M

Detection range	0,5 ... 10 m, depending on the reflective properties
Signal outputs	result of vehicle detection
Outputs	2 potential-free relay contacts, changeover
Supply voltage	1 A / 30 VDC or 0.5 A / 125 VAC
Current consumption	10 ... 30 VDC, optional: 230 VAC
Ambient temperature	approx. 65 mA
Protection degree	-25 bis + 60 °C
Window heater	IP 66
Weight	controlled by thermostat
Dimensions	approx. 2,5 kg
	length 220 mm
	width 180 mm
	height 130 mm
Case	light-alloy, painted grey

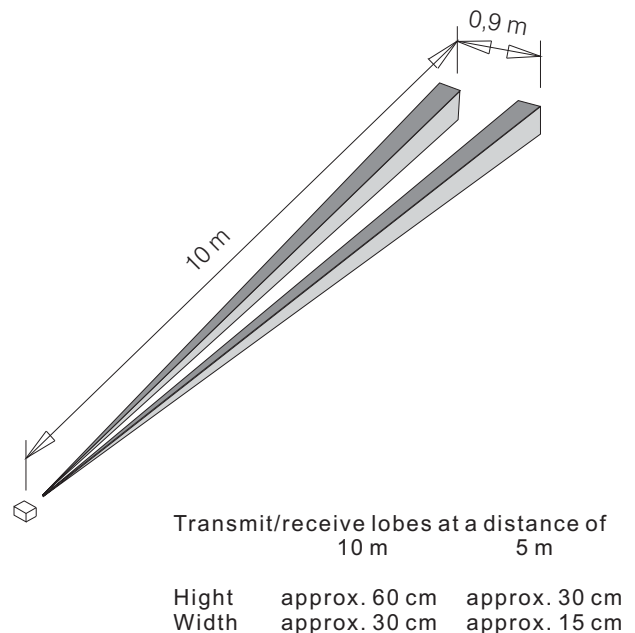

ORDERING INFORMATION

FLG - 10-5M : Vehicle detector, range 10 m
Please indicate power supply,
other reaches and detection ranges on request